

# Romantic Relationships in Immigrants Adolescents

Identity process and Acculturation Experiences

Par Stéphanie Verdon, TCF et psychothérapeute  
RIVO (modifiée de S. Verdon et G. Maher, TCF)

Colloque de la Revue l'Autre  
Octobre 2025

# Presentation Objectives



- Illustrate the interplay between the adolescent identity formation and the family and cultural context
- Demonstrate how teenagers interpersonal relationships are impacted by dimensions of acculturation
- Acknowledge the relevance of cultural genogram in clinical practice with immigrants teenagers and families



# Presentation Outline

- **Theoretical framework**
- **Clinical vignette**
- **Cultural genogram**
- **Theoretical perspectives**

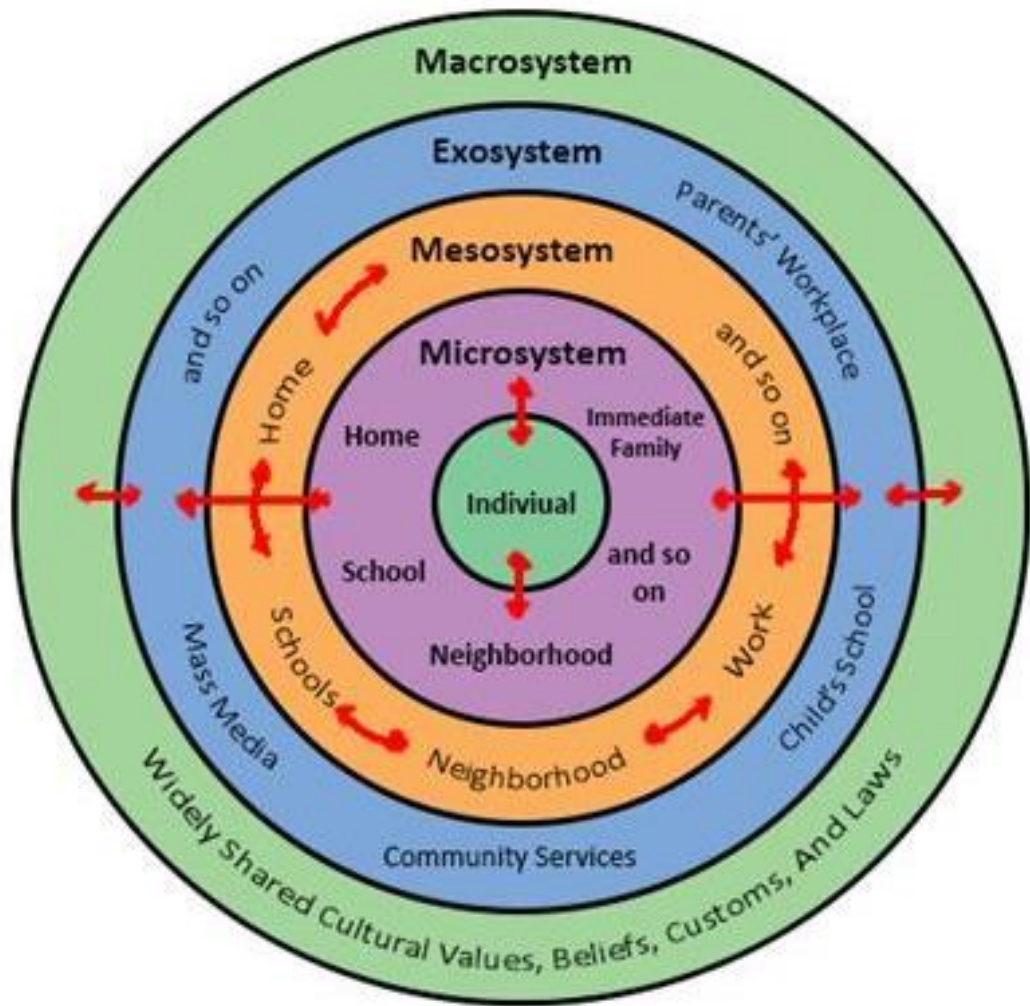

# Theoretical Model Bronfenbrenner

# Clinical Vignette

Zeya, 14 y.o., born in Québec, Pakistanis parents

## **Referral:**

Depressive symptoms, suicidal ideations,  
isolation

- Parents forced break-up in her romantic relationship

## **Follow up :**

June 2018 : ACCESS

Sept 2018 : Individual and Family therapy

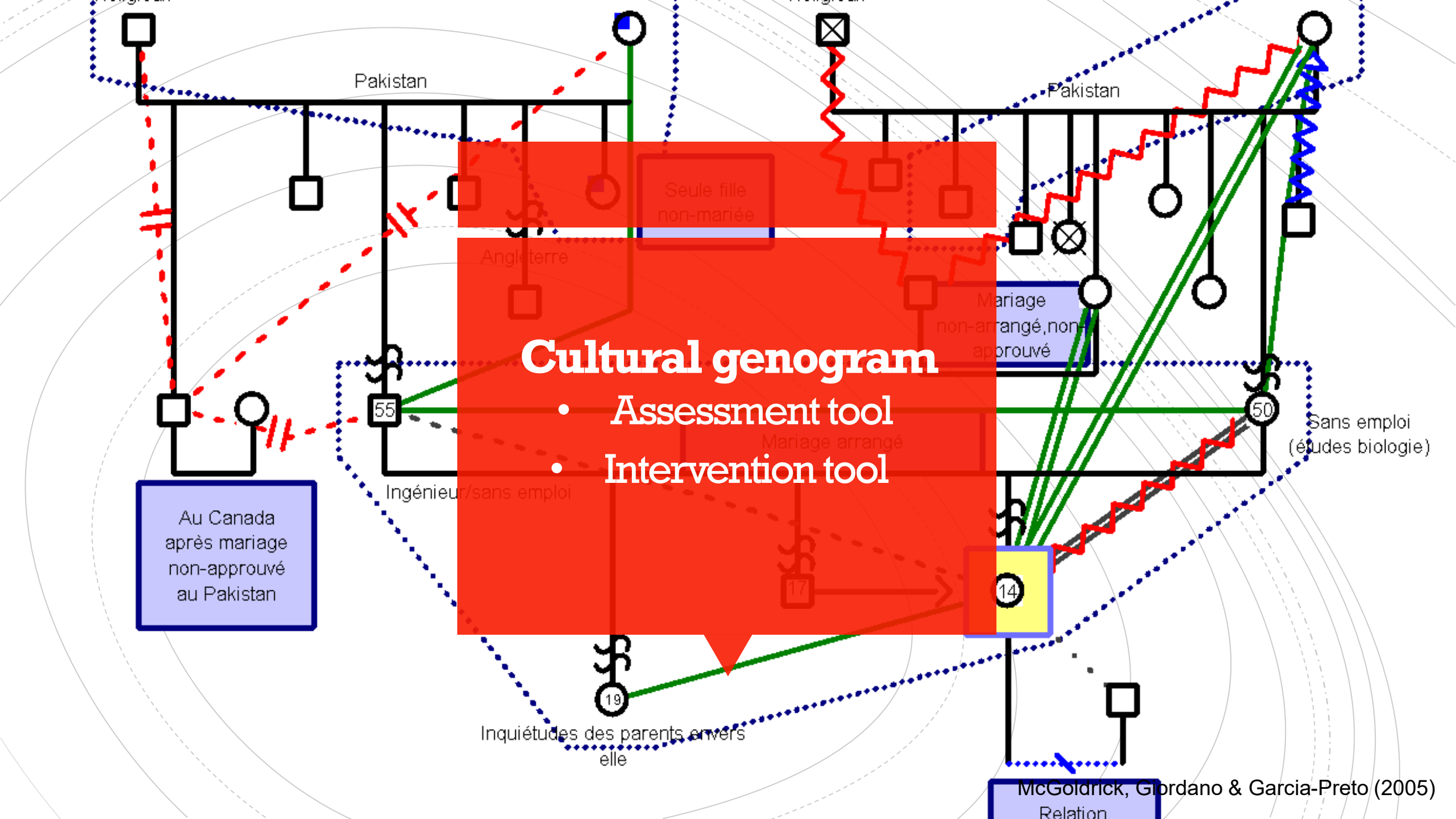



# ONTOSYSTEM

Young People's Identities are Constructed through an Interplay of Group (ethnic, national, racial, religious, gender, etc.) and Personal Identities

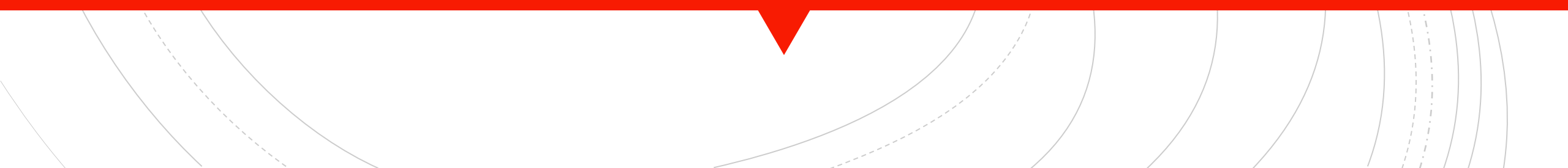

# Identity Perspectives on Adolescence and Migration

- **Third individuation** (Acktar, 1993)
  - Mourning processes
  - 2th or 3<sup>rd</sup> Separation-individuation
  - Identity challenges
  - Splitting
- **Social Identities Theory** (Tajfel & Turner, 1985)
  - Belongingness: integration/change process
  - Self-concept changes
  - Inter-intra groups identities
  - Inhibitors vs facilitators



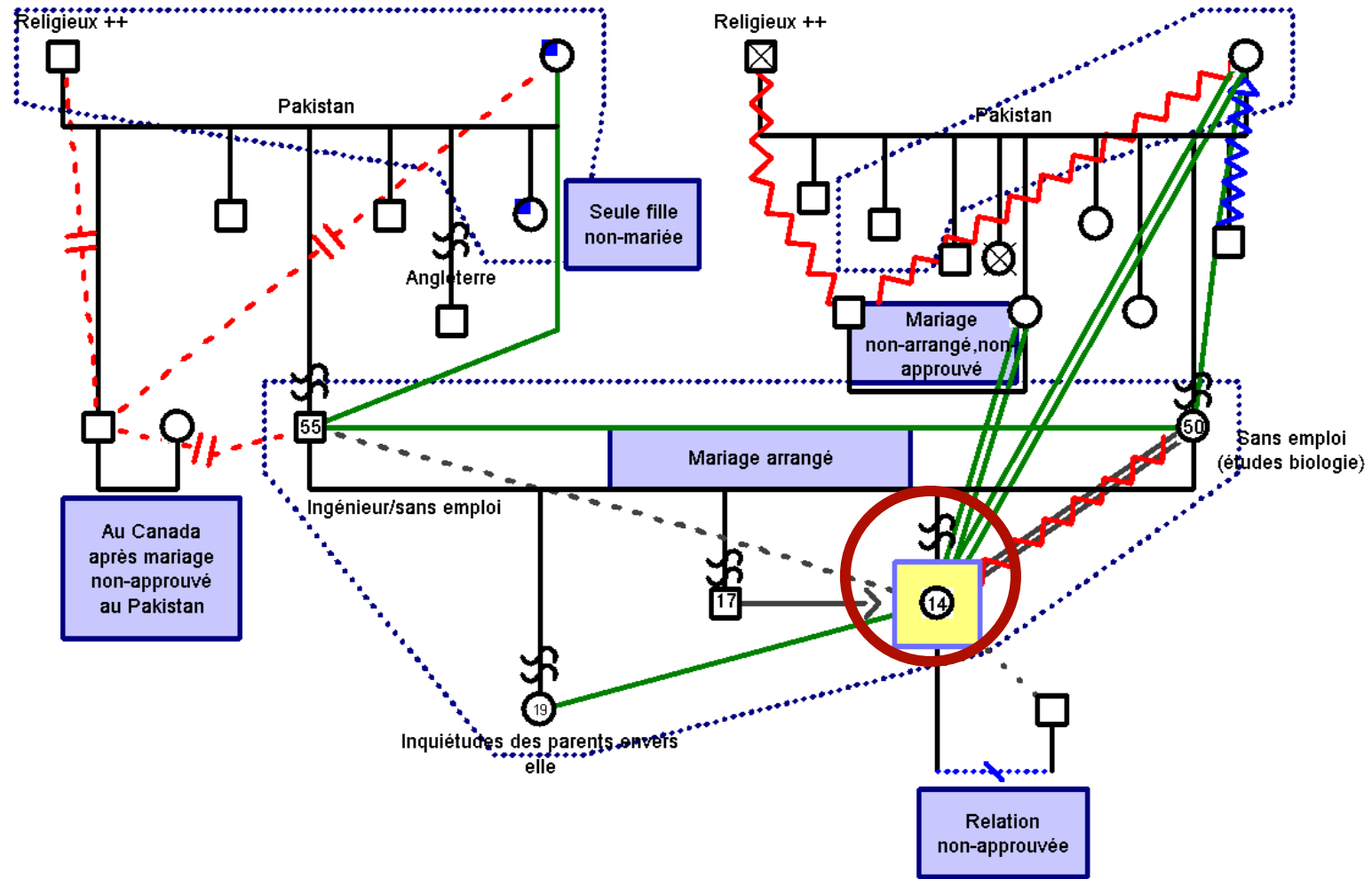

# The Case of Zeya

Genogram

# MICROSYSTEM and Mesosystemic Factors



**Families Acculturation Rhythms and Stressors bring Different Experiences in Romantic Relationships among Immigrant Adolescents**



## Acculturation profiles (Berry, 2016)

Diffuse

Ethnic

National

Integration

Integration  
Separation  
Marginalisation  
Assimilation

## Acculturation attitudes (Berry, 2016)

- **Acculturative stress:** impact on relationship and identity (Berry)
- Acculturation family distancing theory (Hwang & al.)

# Acculturation and Families

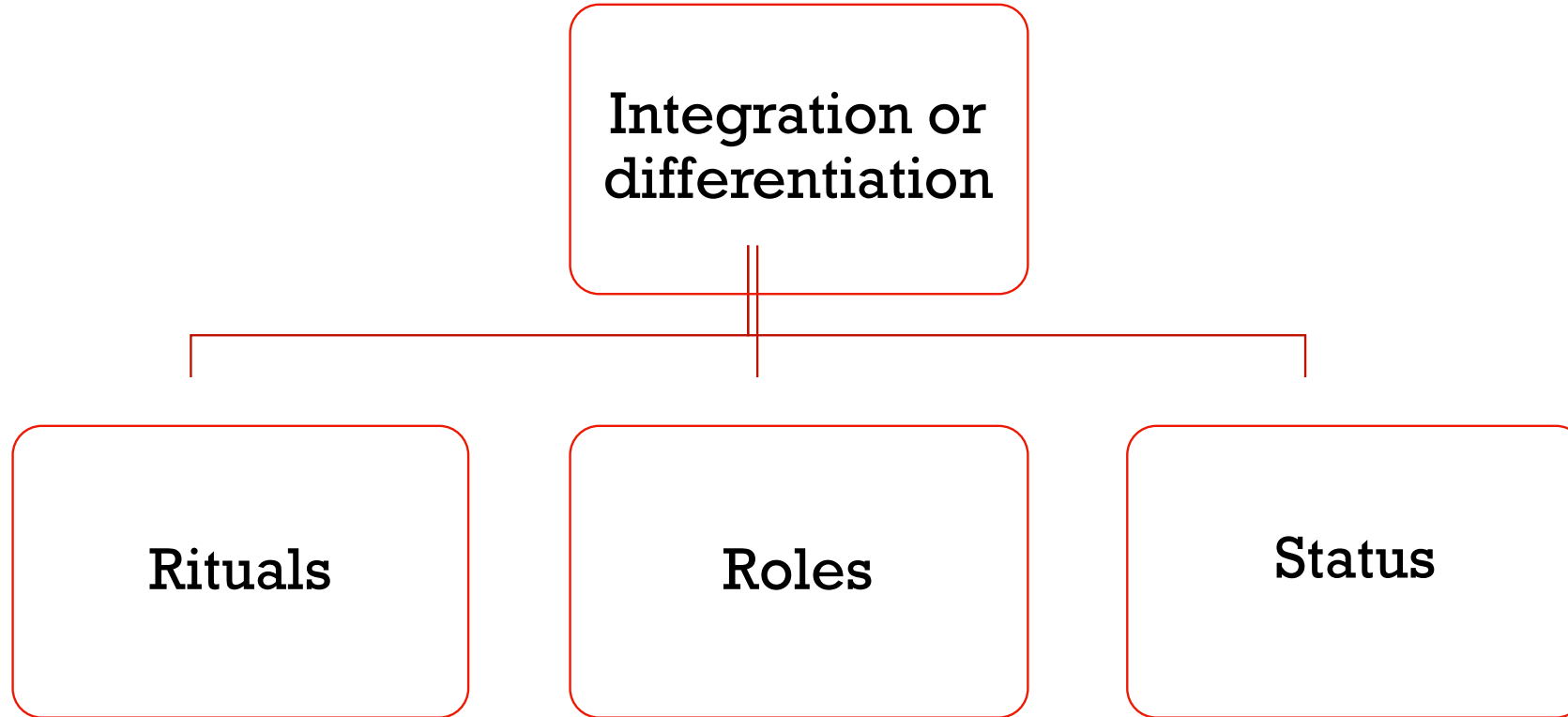

**Romantic Relationship as an Adaptation Strategy to Acculturation**

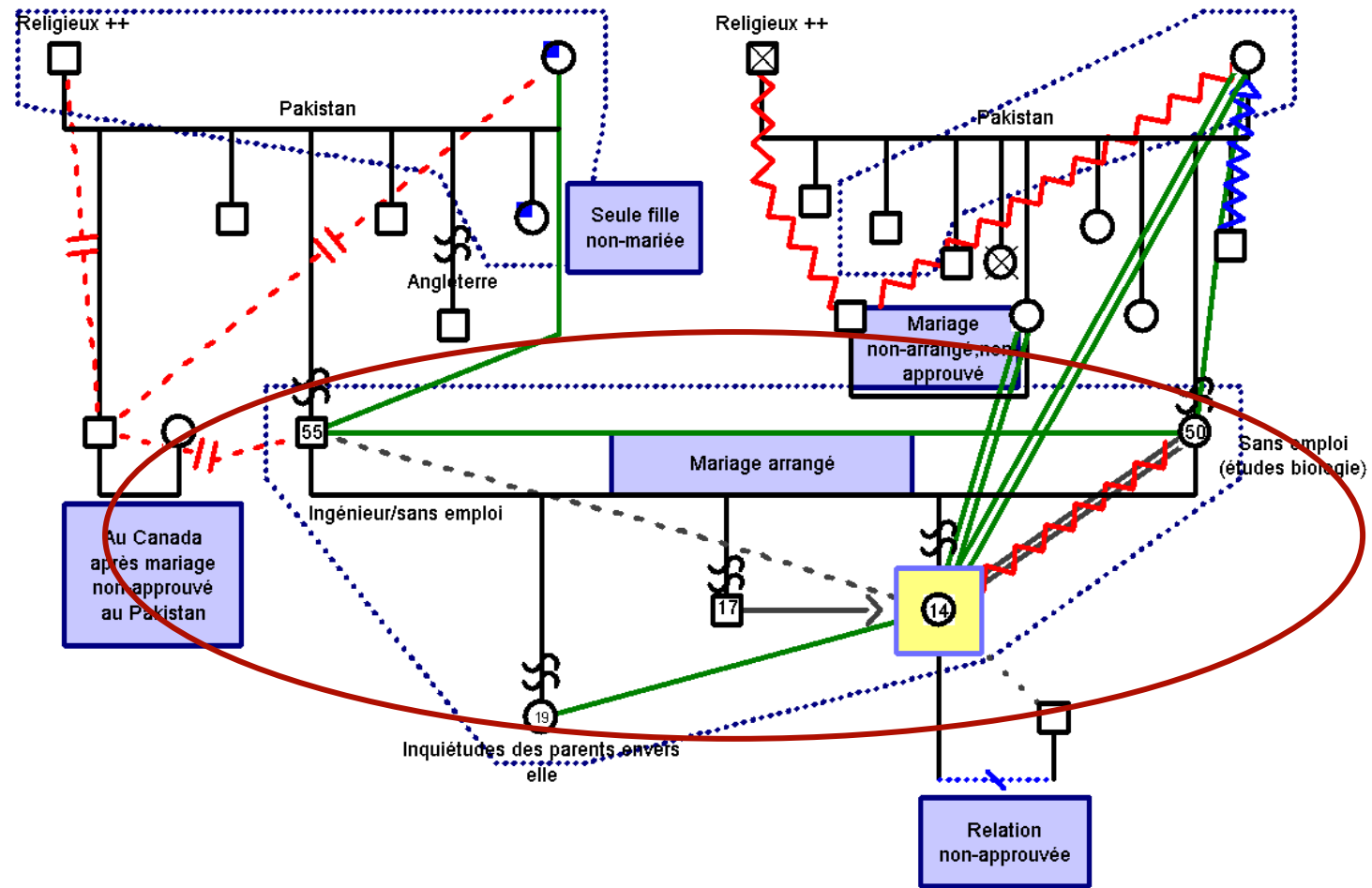

# The Case of Zeya

## Genogram

# MICROSYSTEM



**Parents Preferences  
and Expectations Influence  
Adolescent Romantic Relationships**

# Influences Guiding Preferences in the Choice of Partner

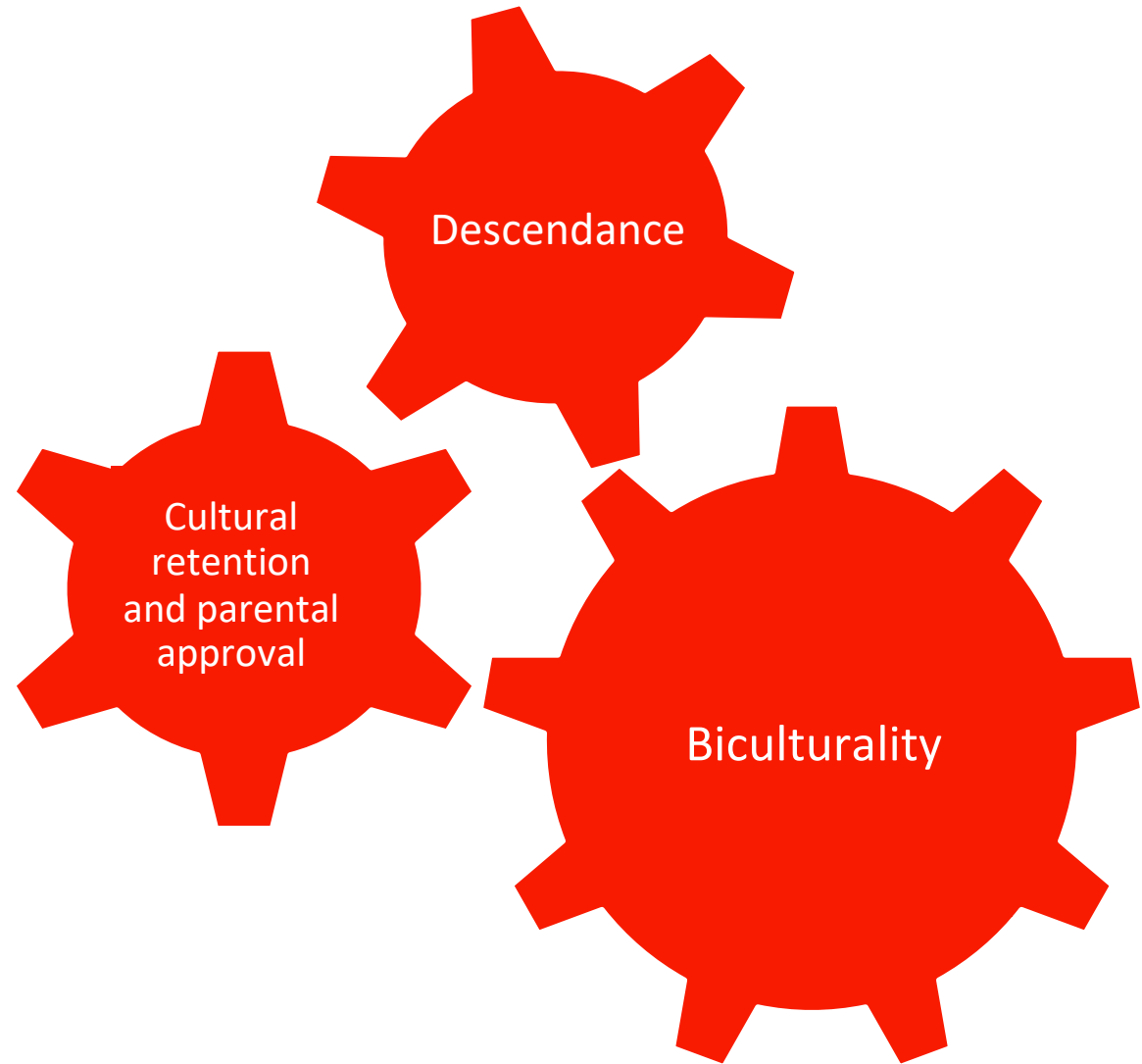

# Degree of Parental Control on Partner Selection

No ingerence

Social  
interactions  
control

Match-maker

Arranged  
marriage





**Conflicts about  
Romantic  
Relationship  
as an Opportunity  
for Intergenerational  
Negotiation**



**Interplay of  
Internal  
Dilemmas**

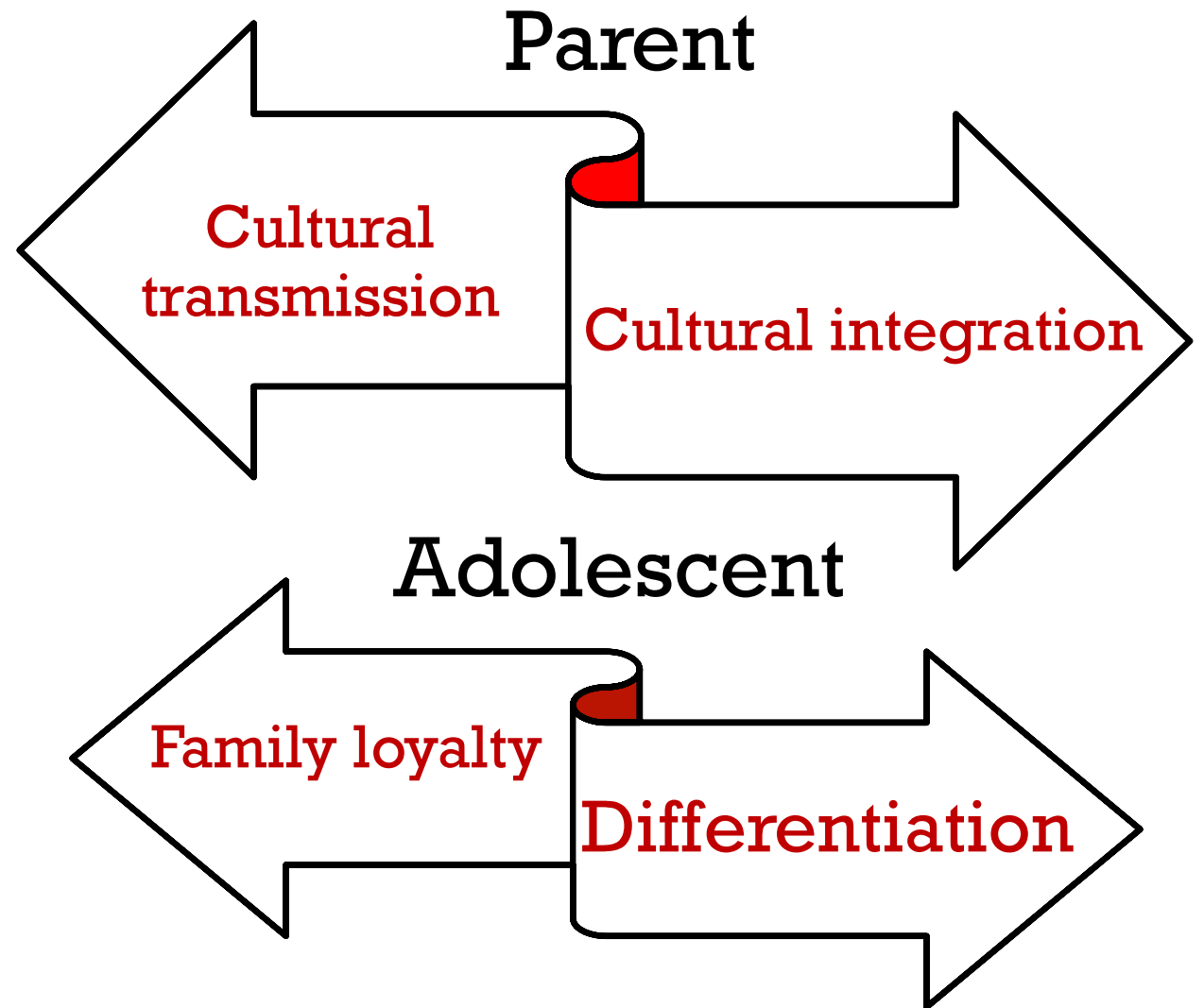

**Family Cohesion and Flexibility**

# Conflicts over Partnership Formation

## **Positive outcomes (minor conflicts)**

- Validating family connections
- Readjusting family norms or creating new ones
- Revisiting power relationships in the family
- \* **Resolution** : acceptance of change of 2 generations and mutual openness

## **Negative outcomes (major conflict)**

- \* **Non-resolution** : “destructive reactions”
- Emphazing rigidity
- Cut-off within families
- Psychological suffering for both generations

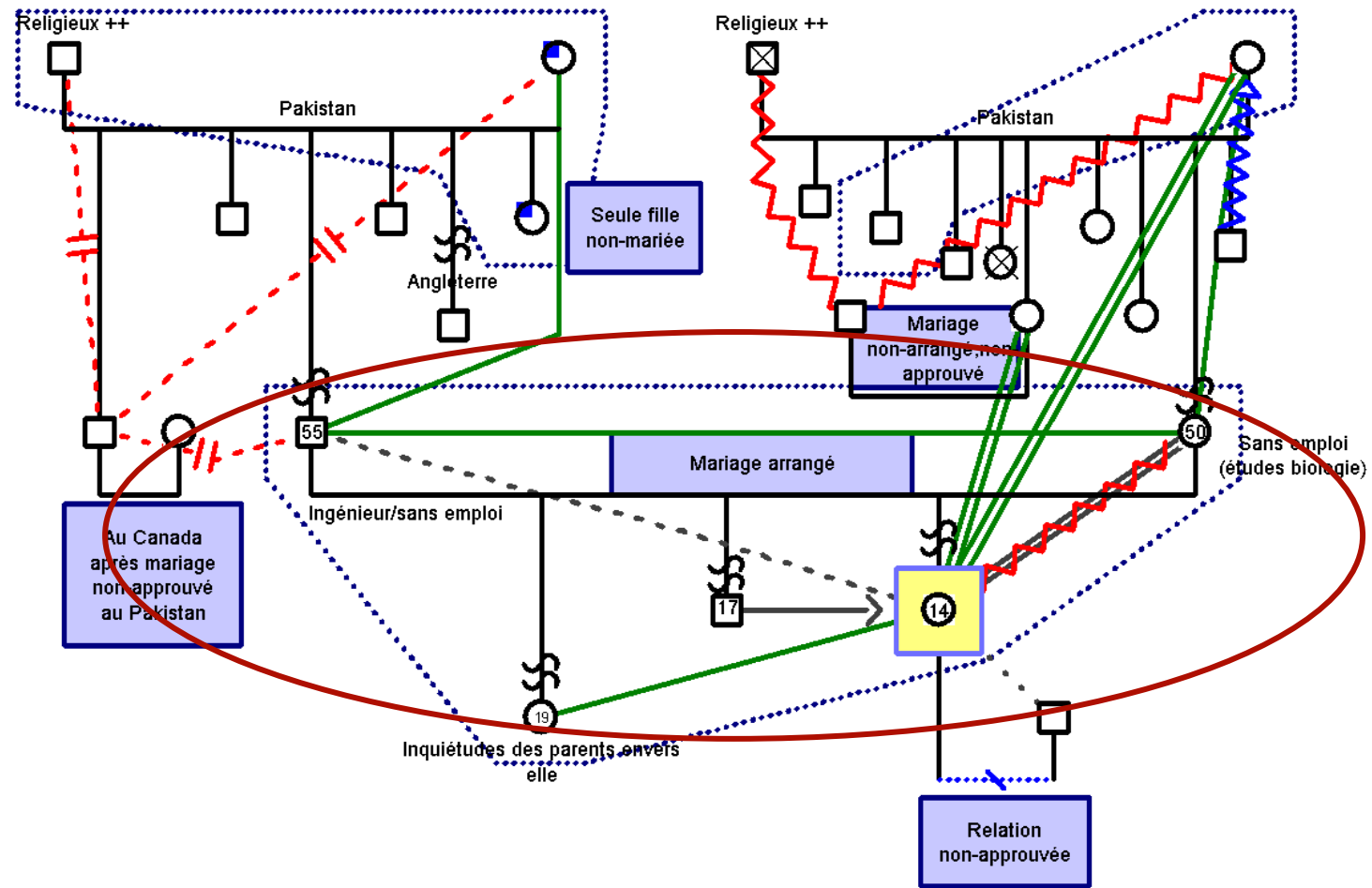

# The Case of Zeya

Genogram

The background features a series of concentric, overlapping circles in white and light gray, creating a ripple effect. The color transitions from a deep red at the top to a bright orange at the bottom.

## MACROSYSTEMIC

Love Relationships are  
Embedded in Cultural  
Paradigms; these  
are Interwoven in  
Social Policies

# Cultural Paradigms as Relational Foundations



Cette photo par Auteur inconnu est soumise à la licence [CC BY-SA](#)

- Family organization and structure
  - Collectivism vs individualism
  - Matrilineal/ patrilineal regimes
  - Cultural expectations in terms of gender
- Honor related violence: discourse focus (Peltola,2017)

(Charsley, 2005; Dion et Dion, 1993; Li et al. 2009; Milbrath, 2017; Shenav et al., 2009; Wikan, 1996)

Cultural expectancies

Sociopolitical background

Cultural beliefs

Socio-economic background

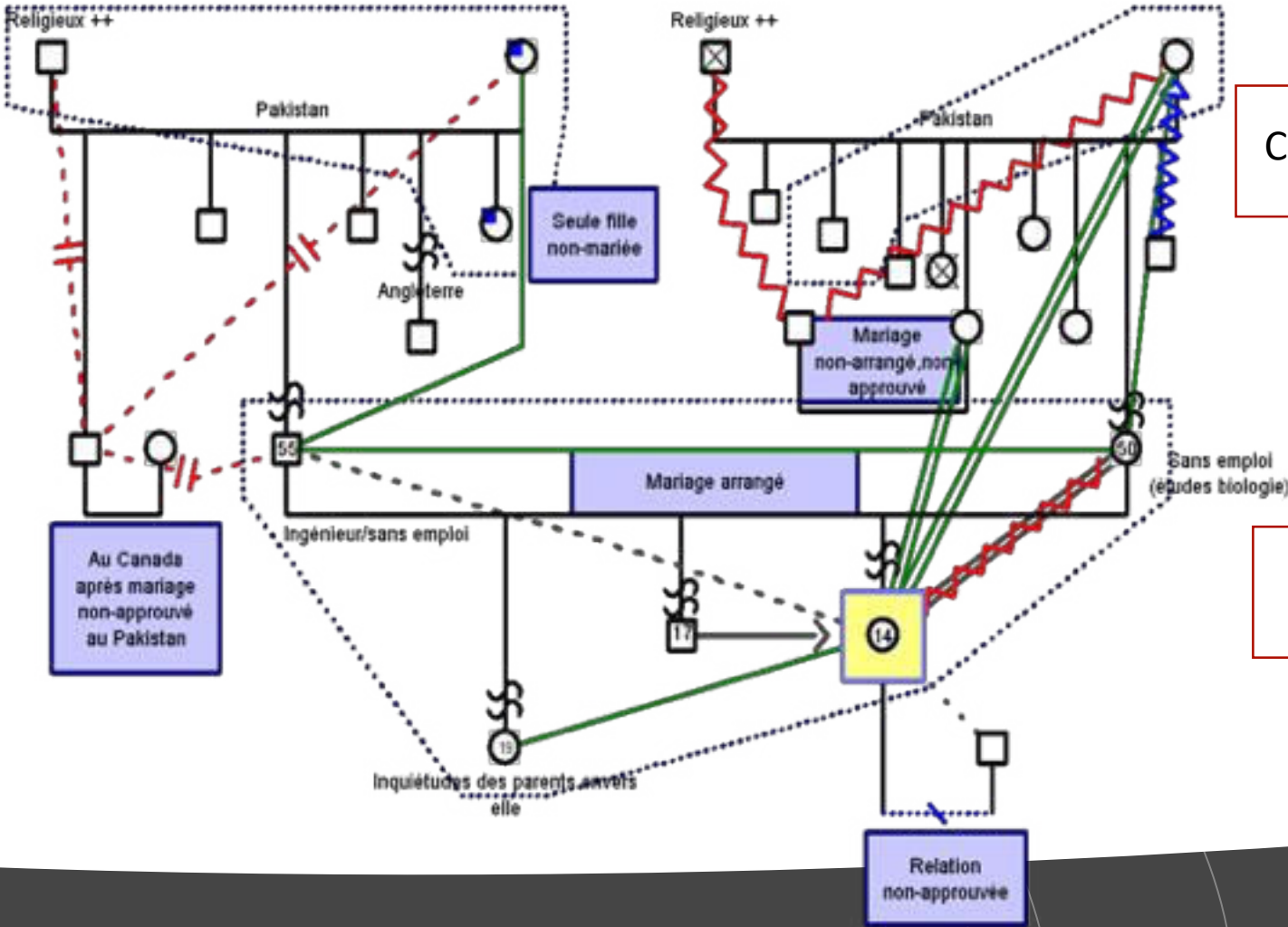

# The Case of Zeya

Genogram



# CHRONOSYSTEM

Timeline Factors Related to the Events and the Life Cycle

**Chronological  
Variables that can  
Impact Adolescent  
Acculturation**

*“Parents may be voluntary or involuntary emigrants, but children are always ‘exiled’: they are not the ones who decide to leave and they cannot decide to return at will”*

*Grinberg and Grinberg 1989, (in Akhtar, 1993)*

- Time in the host country and time in the country of origin
- Developmental stage of the teen and his family
- Generation (1-2-3)
- Earlier vs later in teenagehood
- Family values more integrated at the end of teenagehood: easier to deal with bicultural ality

**Paternal family**

- Relationships with his family of origin and characteristics of his parents
- Stressors/ important events in his life cycle
- Migration process

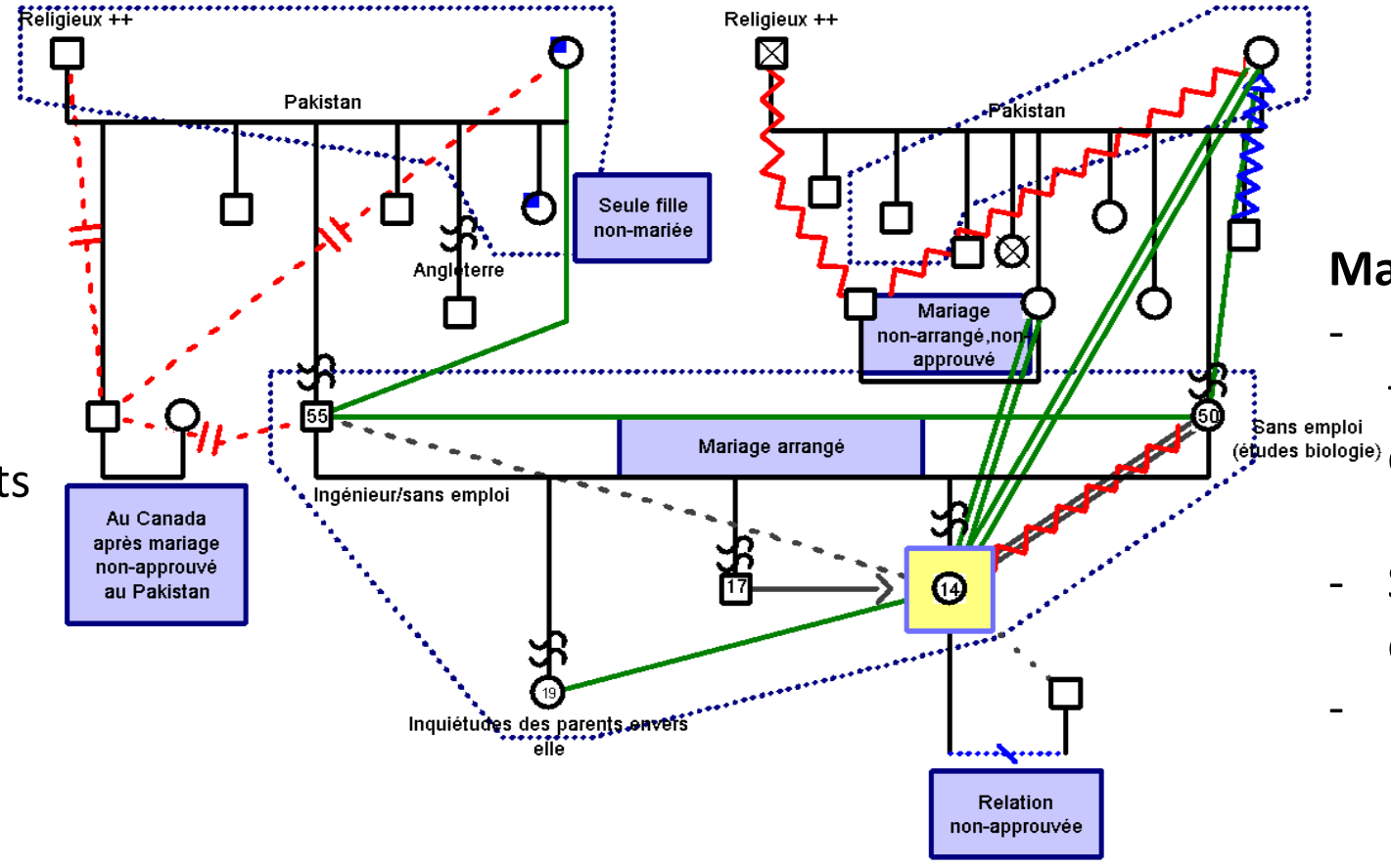

**Maternal family**

- Relationships with her family of origin and characteristics of her parents
- Stressors/ important events in her life cycle
- Migration process

# Zeya's Family Developmental Story

(Pauzé et al., 2017)



**Clinical Implications for  
Interdisciplinary Teams Working  
with Migrant Youth and their Family**

# To Enhance Cultural Sensitivity in Interventions

Assessing and normalizing adaptation process and acculturation stress

Supporting intercultural conflict negotiation

Helping people recognizing immigration challenges and losses

Encouraging transmission of stories from parents to teens

Conceptualizing cultural group differences (inter vs intra groups)

Don't assume that cultural patterns are the same

Showing cultural humility vs sensitivity

Being aware of cultural camouflage

# References

- Akhtar, S. (1995). A third individuation: Immigration, identity, and the psychoanalytic process. *Journal of the American Psychoanalytic Association*, 43(4), 1051-1084.
- Amiot, C. E., de la Sablonnière, R., Terry, D. J., & Smith, J. R. (2007). Integration of Social Identities in the Self: Toward a Cognitive-Developmental Model. *Personality and Social Psychology Review*, 11(4), 364-388.
- Berry, J. W., Phinney, J. S., Sam, D. L., & Vedder, P. (2006). Immigrant youth: Acculturation, identity, and adaptation. *Applied psychology*, 55(3), 303-332.
- Berry (1997). Immigration, Acculturation and Adaptation, *Applied Psychology: An International Review*, 46(1), 5-68.
- Birman, D. (2006). Acculturation gap and family adjustment: Findings with Soviet Jewish refugees in the United States and implications for measurement. *Journal of Cross-Cultural Psychology*, 37(5), 568-589.
- Bowen, M. (1985). *Family therapy in clinical practice*. Jason Aronson.
- Brown, B. B., Larson, R. W., & Saraswathi, T. S. (Eds.). (2002). *The world's youth: Adolescence in eight regions of the globe*. Cambridge University Press.
- Carpentier, J., & de la Sablonnière, R. (2013). Identity Profiles and Well-Being of Multicultural Immigrants: The Case of Canadian Immigrants Living in Quebec. *Frontiers in Psychology*, 4.
- Coates, D. L. (1999). 13 The Cultured and Culturing Aspects of Romantic Experience in Adolescence. The development of romantic relationships in adolescence, 330.

# References (con't)

Crissey, S. R. (2005). Race/ethnic differences in the marital expectations of adolescents: The role of romantic relationships. *Journal of Marriage and Family*, 67(3), 697-709.

Dion, K. K., & Dion, K. L. (1993). Individualistic and Collectivistic Perspectives on Gender and the Cultural Context of Love and Intimacy. *Journal of Social Issues*, 49(3), 53-69.

Davis, E. C., & Friel, L. V. (2001). Adolescent sexuality: Disentangling the effects of family structure and family context. *Journal of marriage and family*, 63(3), 669-681.

Erikson, E. H. (1994). *Identity: Youth and crisis* (No. 7). WW Norton & Company.

Feldman, S. S., Turner, R. A., & Araujo, K. (1999). Interpersonal context as an influence on sexual timetables of youths: Gender and ethnic effects. *Journal of Research on Adolescence*, 9(1), 25-52.

Ford, K., & Norris, A. E. (1993). Urban Hispanic adolescents and young adults: Relationship of acculturation to sexual behavior. *Journal of Sex Research*, 30(4), 316-323.

Gallardo, M. E. (Ed.). (2013). *Developing cultural humility: Embracing race, privilege and power*. SAGE Publications.

Giguère, B., Lalonde, R., & Lou, E. (2010). Living at the Crossroads of Cultural Worlds: The Experience of Normative Conflicts by Second Generation Immigrant Youth. *Social and Personality Psychology Compass*, 4(1), 14-29.

# References (con't)

Guilamo-Ramos, V., Jaccard, J., Pena, J., & Goldberg, V. (2005). Acculturation-related variables, sexual initiation, and subsequent sexual behavior among puerto rican, mexican, and cuban youth. *Health Psychology, 24*(1), 88.

Hassler, S. (2015). A Coherence of Identities or an Identity or Coherence? A Review of the Recent Discussion on Well-Being, Social Identities and Integration in a Multicultural Context. *Building Barriers and Bridges, 11*.

Hernandez, D. J., Denton, N. A., Macartney, S. E., & Society for Research in Child Development (2008). Children in immigrant families: Looking to America's future. *Social Policy Report, 22*(3), 3–22.

Hwang, W. C. (2006). Acculturative family distancing: Theory, research, and clinical practice. *Psychotherapy: Theory, research, practice, training, 43*(4), 397.

Inman, A. G., Howard, E. E., Beaumont, R. L., & Walker, J. A. (2007). Cultural transmission: Influence contextual factors in asian indian immigrant parents' experiences. *Journal of Counseling Psychology, 54*(1), 93.

Li, Z. H., Connolly, J., Jiang, D., Pepler, D., & Craig, W. (2010). Adolescent romantic relationships in China and Canada: A cross-national comparison. *International Journal of Behavioral Development, 34*(2), 113-120.

# References (con't)

Liu, T., Fuller, J., Hutton, A., & Grant, J. (2018). Congruity and Divergence in Perceptions of Adolescent Romantic Experience Between Chinese Parents and Adolescents. *Journal of Adolescent Research*, 0743558418775364.

Luster, T., & Small, S. A. (1994). Factors associated with sexual risk-taking behaviors among adolescents. *Journal of Marriage and the Family*, 622-632.

Madsen, S. D. (2008). Parents' Management of Adolescents' Romantic Relationships Through Dating Rules: Gender Variations and Correlates of Relationship Qualities. *Journal of Youth and Adolescence*, 37(9), 1044-1058.

McGoldrick, M., Gerson, R., & Petry, S. S. (2008). *Genograms: Assessment and intervention*. WW Norton & Company.

Milbrath, C., Ohlson, B., & Eyre, S. L. (2009). Analyzing cultural models in adolescent accounts of romantic relationships. *Journal of Research on Adolescence*, 19(2), 313-351.

Miller, K. S., Forehand, R., & Kotchick, B. A. (1999). Adolescent sexual behavior in two ethnic minority samples: The role of family variables. *Journal of Marriage and the Family*, 85-98.

Musso, P., Inguglia, C., & Lo Coco, A. (2017). Relationships between ethnic identity, ethnic attitudes, and acculturative stress in Tunisian individuals in early and middle adolescence. *The Journal of Early Adolescence*, 37(9), 1309-1340.

# References (con't)

Nesteruk, O., & Gramescu, A. (2012). Dating and Mate Selection Among Young Adults from Immigrant Families. *Marriage & Family Review*, 48(1), 40-58.

Neto, F., Mullet, E., Deschamps, J.-C., Barros, J., Benvindo, R., Camino, L., Machado, M. (2000). Cross-Cultural Variations in Attitudes Toward Love. *Journal of Cross-Cultural Psychology*, 31(5), 626-635.

Pauzé, Robert & Cook-Darzens, Solange & Villeneuve, Marie-Pierre & Chateauneuf, Doris & Petitpas, Judith & Côté Jeffrey. (2017). Evaluation du fonctionnement familial : proposition d'un modèle intégratif pour soutenir la pratique clinique et la recherche. *Thérapie Familiale*. 38. 295. 10.3917/tf.173.0295.

Peltola, M., Keskinen, S., Honkasalo, V., & Honkatukia, P. (2017). Intergenerational negotiations on (hetero)sexuality and romantic relationships – views of young people and parents in multi-ethnic contexts. *Journal of Youth Studies*, 20(5), 533-548

Phinney, J. S. (1989). Stages of ethnic identity development in minority group adolescents. *The Journal of Early Adolescence*, 9(1-2), 34-49.

Rincón, A. M. (2009). Practicing cultural humility. *Foundations for community health workers*, 35, 135.

Rousseau, C., Gauthier, M.-F., Lacroix, L., Alain, N., Benoit, M., Moran, A., ... Bourassa, D. (2005). Playing with identities and transforming shared realities: drama therapy workshops for adolescent immigrants and refugees. *The Arts in Psychotherapy*, 32(1), 13-27

# References (con't)

Rumbaut, R. G. (1994). The crucible within: Ethnic identity, self-esteem, and segmented assimilation among children of immigrants. *International migration review*, 28(4), 748-794.

Sabatier, C., & Berry, J. W. (2008). The role of family acculturation, parental style, and perceived discrimination in the adaptation of second-generation immigrant youth in France and Canada. *European journal of developmental psychology*, 5(2), 159-185.

Schwartz, S. J., Weisskirch, R. S., Zamboanga, B. L., Castillo, L. G., Ham, L. S., Huynh, Q. L., ... & Davis, M. J. (2011). Dimensions of acculturation: Associations with health risk behaviors among college students from immigrant families. *Journal of counseling psychology*, 58(1), 27.

Singla, R. (2006). Intimate Partnership Formation and Intergenerational Relationships among Ethnic Minority Youth in Denmark. *Outlines. Critical Practice Studies*, 8(2), 76-97.

Sirin, S. R., Ryce, P., Gupta, T., & Rogers-Sirin, L. (2012). The role of acculturative stress on mental health symptoms for immigrant adolescents: A longitudinal investigation. *Developmental Psychology*, 49(4), 736.

Shehan, C. L. (Ed.). (2016). *The Wiley Blackwell Encyclopedia of Family Studies*, 4 Volume Set (Vol. 1). John Wiley & Sons

# References (con't)

- Shenhav, S., Campos, B., & Goldberg, W. A. (2017). Dating out is intercultural: Experience and perceived parent disapproval by ethnicity and immigrant generation. *Journal of Social and Personal Relationships*, 34(3), 397-422.
- Sullivan, C., & Cottone, R. R. (2006). Culturally Based Couple Therapy and Intercultural Relationships: A Review of the Literature. *The Family Journal*, 14(3), 221-225.
- Szapocznik, J., Rio, A., Perez-Vidal, A., Kurtines, W., Hervis, O., & Santisteban, D. (1986). Bicultural Effectiveness Training (BET): An Experimental Test of an Intervention Modality for Families Experiencing Intergenerational/Intercultural Conflict. *Hispanic Journal of Behavioral Sciences*, 8(4), 303-330.
- Yahyaoui, A., El Methni, M., Lakhdar, D. B. H., & Gaultier, S. (2010). Représentations et vécus de la sexualité à l'adolescence et appartenances culturelles. Étude comparative auprès de 134 adolescentes. *Neuropsychiatrie de l'enfance et de l'adolescence*, 58(3), 132-139.
- Zaidi, A. U., & Shurady, M. (2002). Perceptions of Arranged Marriages by Young Pakistani Muslim Women Living in a Western Society. *Journal of Comparative Family Studies*, 33(4), 495-514.